

The AW-CSS2167EX Strobe-Sounder have excellent explosion-proof performance. it is suitable for hazardous locations which include explosive gas environment.

The AW-CSS2167EX can be used with manual alarm button to make up a simple alarm-system. And it can be used with the most fire alarm panel system.

The AW-CSS2167EX combine the louder speaker and ultra-bright LED, it has long services life and low power consumption.

The AW-CSS2167EX have 3 sound pattern options: Fire Alarm Sound, Police Car Sound, Ambulance Sound.

## Features

- ✓ Ultra-Bright LED
- ✓ Louder Alarm Sound Level
- ✓ Excellent explosion-proof performance
- ✓ strong anti-corrosion

Noted: This products need to use with Explosion-proof bracket

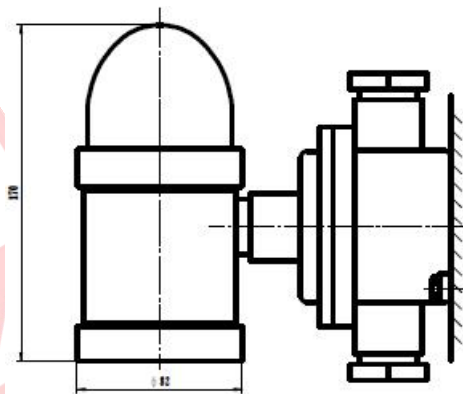
## Technical Specification

Model	AW-CSS2167EX
Voltage	DC24V
Alarm current	650mA
Sound (SPL)	110~120dB
Ex-Atex Protection Level	Exd II C T6 Gb
Outlet Thread	G20 (can be customized)
Environmental	Temperature range: -20 to 50°C (-4~122°F) Humidity: 5 to 95% RH, non-condensing
Materials and colors	Stainless Steel, PC, RED
Size	82mm* 82mm* 170mm
Weight	about 2.4kg